

Mill Operator Users Guide

MAX 5 Console

HURCO[®]

Mike Cope
Product Technical Specialist
copem@hurco.com

Table of Contents

- Performing a Tool Change
- Clear the Tool in Spindle
- Tool Touch-off
 - Without touch probe
 - With touch probe
- Part Setup
 - Without part probe
- Absolute Tool Length Calibration Defined

Performing a Toolchange

Performing a Manual Toolchange

1. Press the MANUAL mode button on the control panel
2. Press INPUT on control panel
3. Select TOOL REVIEW softkey
4. Select TOOL SETUP softkey
5. Enter the desired tool number and press ENTER

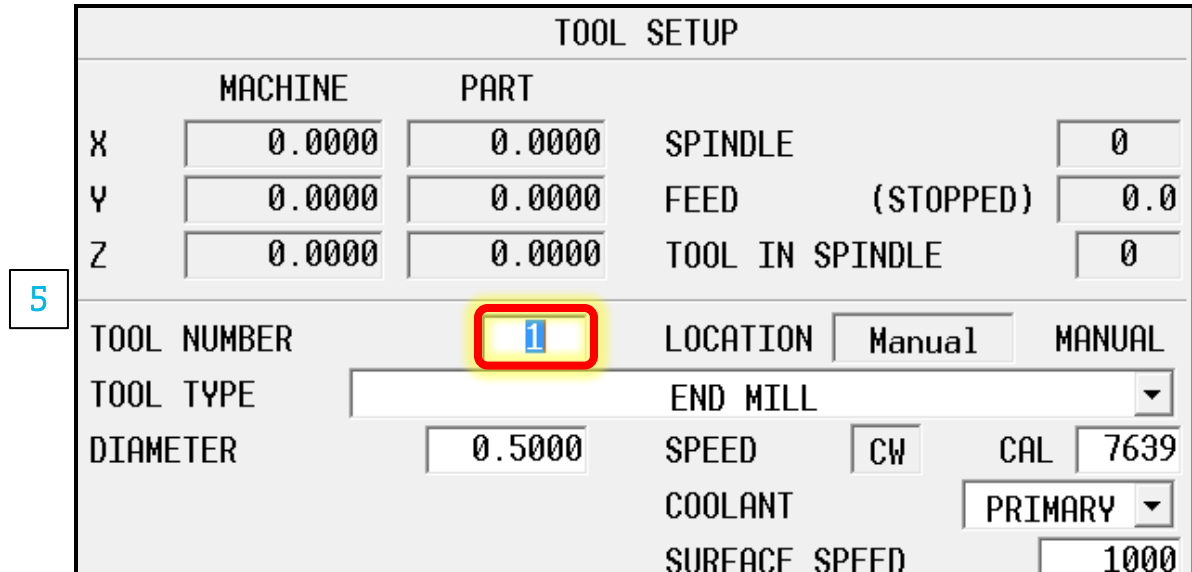

Performing a Manual Toolchange

6. Press the Tool Changer AUTO button - START CYCLE should begin to flash
7. Press the flashing START CYCLE button
8. Verify the AUTO/MANUAL state of the current tool - use the Tool Changer Auto button to toggle the AUTO/MANUAL condition of the tool

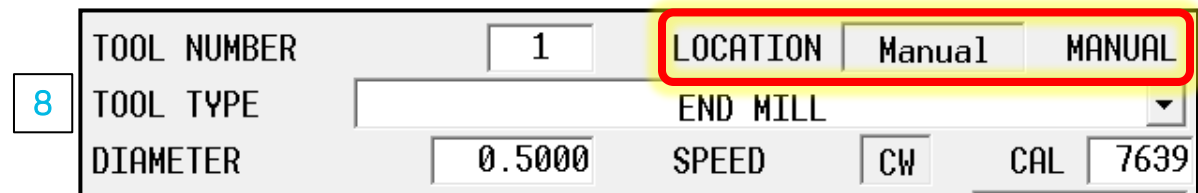

Clear Tool in Spindle

Clearing the Tool in Spindle

1. Press the MANUAL mode button on the control panel
2. Select TOOL MANAGEMENT softkey
3. Select CLEAR TOOL IN SPINDLE softkey
4. Press the flashing START CYCLE button

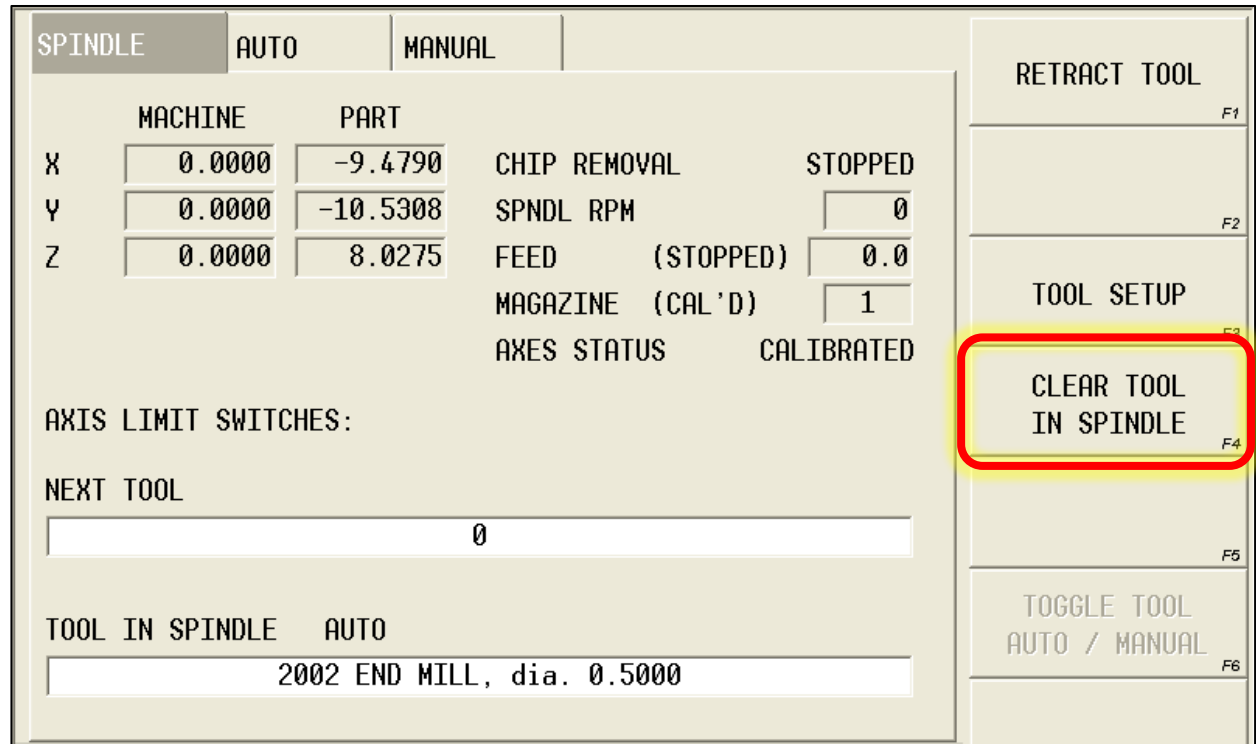

Tool Touch-off

Without Tool Touch Probe

Note: the tool setup and touch-off procedures in this manual assume that the machine control has been setup in *Absolute Tool Length* mode. Please refer to the separate section at the end of this document for more details.

TOOL SETUP						DELETE TOOL		
	MACHINE	PART						
X	0.0000	0.0000	SPINDLE		0		F1	
Y	0.0000	0.0000	FEED (STOPPED)		0.0			
Z	0.0000	0.0000	TOOL IN SPINDLE		0			
TOOL NUMBER	1		LOCATION	Manual	MANUAL			
TOOL TYPE			END MILL					
DIAMETER	0.5000		SPEED	CW	CAL	7639		
TOOL CAL LENGTH	6.2531							
TOUCH-OFF DEVICE	1	GAUGE						
			CUTTING TIME		21			
			DIAMETER WEAR		0.0000			

Amount of time in minutes that the tool has been in the rotating spindle.
PRESS MANUAL MODE, POWER, AND START CYCLE TO RESTORE POWER.



The absolute length of the tool, measured from the spindle gage-line.

Step 1

Verify the Active Device

1. Press INPUT on control panel
2. Select TOOL REVIEW softkey
3. Select TOOL SETUP softkey
4. Select MORE softkey
5. Select TOOL MEASUREMENT SETTINGS softkey
6. Select the active Touch-off device

TOOL MEASUREMENT SCREEN

TOUCH-OFF DEVICE 50mm Dial Height Gage

	DEVICE	HEIGHT	Z LOCATION	
1	<input type="text" value="GAUGE"/>	<input type="text" value="1.9685"/>	<input type="text" value="-21.5753"/>	CAL
2	<input type="text" value="GAUGE"/>	<input type="text" value="2.0000"/>	<input type="text" value="-21.5438"/>	CAL
3	<input type="text" value="GAUGE"/>	<input type="text" value="1.9685"/>	<input type="text" value="-21.5753"/>	CAL
4	<input type="text" value="GAUGE"/>	<input type="text" value="3.0000"/>	<input type="text" value="-20.5438"/>	CAL
5	<input type="text" value="GAUGE"/>	<input type="text" value="0.0000"/>	<input type="text" value="0.0000"/>	
6	<input type="text" value="GAUGE"/>	<input type="text" value="6.0000"/>	<input type="text" value="-17.5438"/>	CAL

NOTES Z REFERENCE

Enter the height of the measurement device, relative to the Z reference location.

Step 2

Calibrate the Tool

1. Jog the tool into contact with the active touch-off device using the hand-wheel
2. Store the tool length by pressing the SET LENGTH USING TOUCH-OFF DEVICE softkey (F6)



TOOL SETUP					
	MACHINE	PART			
X	15.0000	-0.0672	A	0.000	-0.000
Y	20.0000	10.7971	C	0.000	-0.000
Z	0.0000	17.5638	TOOL IN SPINDLE	0	
TOOL NUMBER	10		LOCATION	Manual	
TOOL TYPE			END MILL	▼	
DIAMETER	0.5000		SPEED	CW	CAL 8403
			COOLANT	PRIMARY ▼	
			SURFACE SPEED	1100	
TOOL CAL LENGTH	7.625		FEED/FLUTE	0.005000	
TOUCH-OFF DEVICE	3 GAUGE		FLUTES	2	
			FEED	CAL	84.0
			CUTTING TIME	21	
			DIAMETER WEAR	0.0000	

Enter or store the tool calibration value.
'P' designator indicates values set by probing.

DELETE TOOL F1
PART SETUP F2
PART PROGRAMMING F3
TOOL OFFSETS F4
TOOL HOME F5
SET LENGTH USING TOUCH-OFF DEVICE F6
MORE → F7
EXIT F8

Tool Touch-off

With Tool Touch Probe

Note: the tool setup and touch-off procedures in this manual assume that the machine control has been setup in *Absolute Tool Length* mode. Please refer to the separate section at the end of this document for more details.

TOOL SETUP						DELETE TOOL		
	MACHINE	PART						
X	0.0000	0.0000	SPINDLE		0		F1	
Y	0.0000	0.0000	FEED (STOPPED)		0.0			
Z	0.0000	0.0000	TOOL IN SPINDLE		0			
TOOL NUMBER	1		LOCATION	Manual	MANUAL			
TOOL TYPE			END MILL					
DIAMETER	0.5000		SPEED	CW	CAL	7639		
TOOL CAL LENGTH	6.2531							
TOUCH-OFF DEVICE	1	GAUGE						
			CUTTING TIME		21			
			DIAMETER WEAR		0.0000			

Amount of time in minutes that the tool has been in the rotating spindle.
PRESS MANUAL MODE, POWER, AND START CYCLE TO RESTORE POWER.



The absolute length of the tool, measured from the spindle gage-line.

Step 1

Verify Probing Cycle Defaults

1. Press INPUT on control panel
2. Select TOOL REVIEW softkey
3. Select TOOL SETUP softkey
4. Select MORE softkey
5. Select TOOL PROBING softkey
6. Select TOOL PROBE SETUP softkey
7. Select TOOL PROBING CYCLE DEFAULTS softkey

TOOL PROBING CYCLE DEFAULTS

Recommended Default Settings

SPINDLE USAGE	MANUAL	LENGTH OFFSET X	0.0000
SPINDLE SPEED	0	LENGTH OFFSET Y	0.0000
FAST FEED	25.0	Z DROP DOWN DEPTH	0.2500
SLOW FEED	3.0	SPINDLE CLEARANCE	0.1250
RAPID CLEARANCE	0.3937		
MIN LENGTH DELTA	1.0000		

STORE RESULT AS

LENGTH	TOOL LENGTH
DIAMETER	DIAMETER WEAR

Specify how the spindle will operate during the tool probing cycle.

Step 2

Probe the Tool

1. Press INPUT on control panel
2. Select TOOL REVIEW softkey
3. Select TOOL SETUP softkey
4. Select MORE softkey
5. Select TOOL PROBING softkey
6. Measure tool for reference length, and enter the value in the TOOL CAL LENGTH field

TOOL PROBING				
	MACHINE	PART		
X	0.0000	0.0000	SPINDLE	0
Y	0.0000	0.0000	FEED (STOPPED)	0.0
Z	0.0000	0.0000	TOOL IN SPINDLE	0
TOOL	1 END MILL, dia. 0.5000			
<input type="checkbox"/> EDIT PARAMETERS	TOOL CAL LENGTH			6.2500
MAIN	LENGTH	DIAMETER		
CYCLE	LENGTH & DIAMETE		FAST FEED	25.0
RAPID CLEARANCE	0.3937		SLOW FEED	3.0
RAPID Z POSITION	-10.1131		MIN LENGTH DELTA	1.0000
SPINDLE USAGE	MANUAL		MIN Z POSITION	-11.5068
			MULTI TOOL PROBING	NO
SISTER TOOL	0			
Enter an estimated tool length before probing the tool. The value is used to calculate the Rapid Z Position.				

6

Step 2 - Continued

Probe the Tool

7. Check the EDIT PARAMETERS box to allow editing of the default probing parameters – **only if needed** – be sure to check all 3 tabs (Main, Length, Diameter).
8. Select the desired cycle type
9. Select the PROBE CURRENT TOOL NOW softkey

Note: the travel speed of the probe is controlled by the FEED knob only.

TOOL PROBING			
MACHINE	PART	SPINDLE	0
X 0.0000	0.0000	FEED (STOPPED)	0.0
Y 0.0000	0.0000	TOOL IN SPINDLE	0
Z 0.0000	0.0000		
TOOL	1 END MILL, dia. 0.5000		
<input checked="" type="checkbox"/> EDIT PARAMETERS	TOOL CAL LENGTH	6.2500	
MAIN	LENGTH	DIAMETER	
CYCLE	LENGTH & DIAMETE	FAST FEED	25.0
RAPID CLEARANCE	0.3937	SLOW FEED	3.0
RAPID Z POSITION	-10.1131	MIN LENGTH DELTA	1.0000
SPINDLE USAGE	MANUAL	MIN Z POSITION	-11.5068
		MULTI TOOL PROBING	NO
SISTER TOOL	0		
Enter an estimated tool length before probing the tool. The value is used to calculate the Rapid Z Position.			
EXIT			

TOOL PROBE SETUP F1

CALIBRATE THE TOOL PROBE F2

PROBE SINGLE TOOL F3

PROBE MULTIPLE TOOLS F4

POSITION TOOL OVER PROBE F5

PROBE CURRENT TOOL NOW F6

9

Part Setup

Without Part Probe

Part Setup Screen

Note: the default configuration for the part setup screen is in the Universal Rotary setting. Regardless of the machine configuration (3-axis, 4-axis, or 5-axis) there will be data fields for a IV and V axis. This is normal, and the fields can be ignored for standard 3-axis machines.

PART SETUP					
MACHINE		PART		WORK OFFSETS <small>F1</small>	
X	0.0000	0.0000	SPINDLE	0	
Y	0.0000	0.0000	FEED (STOPPED)	0.0	TOOL SETUP <small>F2</small>
Z	0.0000	0.0000	TOOL IN SPINDLE	0	
PART ZERO		SHIFT	SAFETY WORK REGION		PART PROGRAMMING <small>F3</small>
X	0.0000		(-) (+)		
Y	0.0000		Z	-399.0000 399.0000	PROGRAM PARAMETERS <small>F4</small>
Z	0.0000	0.0000	X	-399.0000 399.0000	
IV	0.000		Y	-399.0000 399.0000	PART PROBING <small>F5</small>
V	0.000				
				X/Y SKEW (DEG)	0.0000
STORE MACHINE POSITION <small>F6</small>					
MORE → <small>F7</small>					
EXIT <small>F8</small>					

Enter part zero.

Part Setup

Without Part Probe

1. Press INPUT on control panel
2. Select PART SETUP softkey
3. Jog the desired axis into position using the handwheel
4. Place the cursor in the corresponding data field for the desired axis
5. Select the STORE MACHINE POSITION softkey
6. Verify the data is correct

PART SETUP						WORK OFFSETS	
	MACHINE	PART	SPINDLE			F1	
X	0.0000	0.0000	0				
Y	0.0000	0.0000	FEED (STOPPED)		0.0		
Z	0.0000	0.0000	TOOL IN SPINDLE		0	F2	
	PART ZERO	SHIFT	SAFETY WORK REGION		PART PROGRAMMING		
			(-) (+)		F3		
X	0.0000		Z	-399.0000 399.0000	PROGRAM PARAMETERS		
Y	0.0000		X	-399.0000 399.0000	F4		
Z	0.0000	0.0000	Y	-399.0000 399.0000	PART PROBING		
IV	0.000				F5		
V	0.000				STORE MACHINE POSITION		
			X/Y SKEW (DEG)	0.0000	F6		
Enter part zero.						MORE →	
PRESS MANUAL MODE, POWER, AND START CYCLE TO RESTORE POWER.						EXIT	
						F7	
						F8	

Part Setup Screen

Note: the SHIFT field can be used to incrementally shift the Z-axis.
For example: a value of 2.0000" will shift the Z-axis zero in the positive direction by two inches. Both positive and negative values can be input.

PART SETUP					
	MACHINE	PART			
X	<input type="text" value="0.0000"/>	<input type="text" value="-18.6155"/>	SPINDLE	<input type="text" value="0"/>	
Y	<input type="text" value="0.0000"/>	<input type="text" value="-12.4577"/>	FEED	(STOPPED)	<input type="text" value="0.0"/>
Z	<input type="text" value="0.0000"/>	<input type="text" value="16.4932"/>	TOOL IN SPINDLE	<input type="text" value="0"/>	
	PART ZERO	SHIFT	SAFETY WORK REGION		
			(-)	(+)	
X	<input type="text" value="18.6155"/>		Z	<input type="text" value="-399.0000"/>	<input type="text" value="399.0000"/>
Y	<input type="text" value="12.4577"/>		X	<input type="text" value="-399.0000"/>	<input type="text" value="399.0000"/>
Z	<input type="text" value="-18.4932"/>	<input type="text" value="2.0000"/>	Y	<input type="text" value="-399.0000"/>	<input type="text" value="399.0000"/>
IV	<input type="text" value="0.000"/>				
V	<input type="text" value="0.000"/>				

Absolute Tool Length Calibration

HURCO[®]

Mike Cope
Product Technical Specialist
copem@hurco.com

Contents

- What is Absolute Tool Length
- What is the Spindle Gage-line
- What is a Master Reference Tool
- How is the Gage-line calculated
- Why is it important to use the Gage-line for tool lengths
- How to establish a Probe or Gauge device.

Absolute Tool Length

What is it?

Absolute Tool Length - is the actual measured length of a tool sticking out of the spindle, and is typically measured from the spindle gage-line.

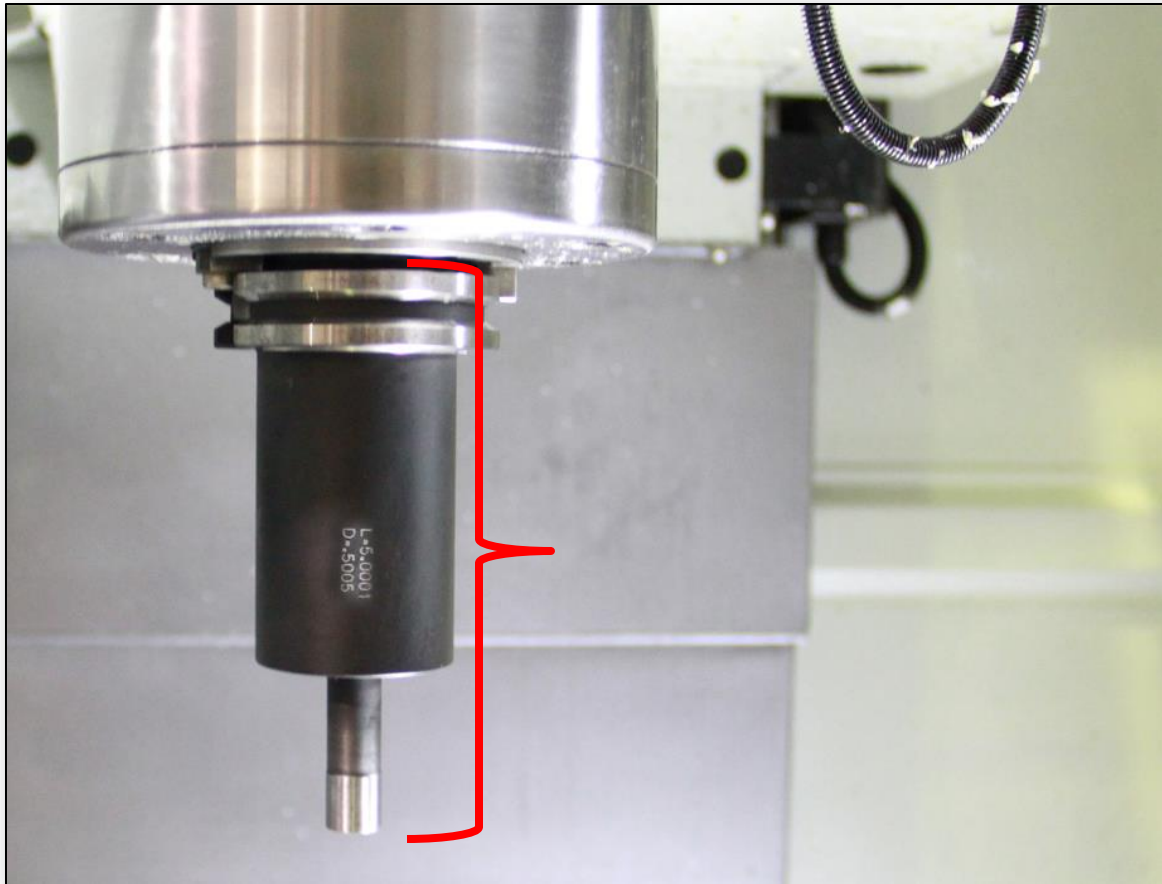

Spindle Gage-line

What is it?

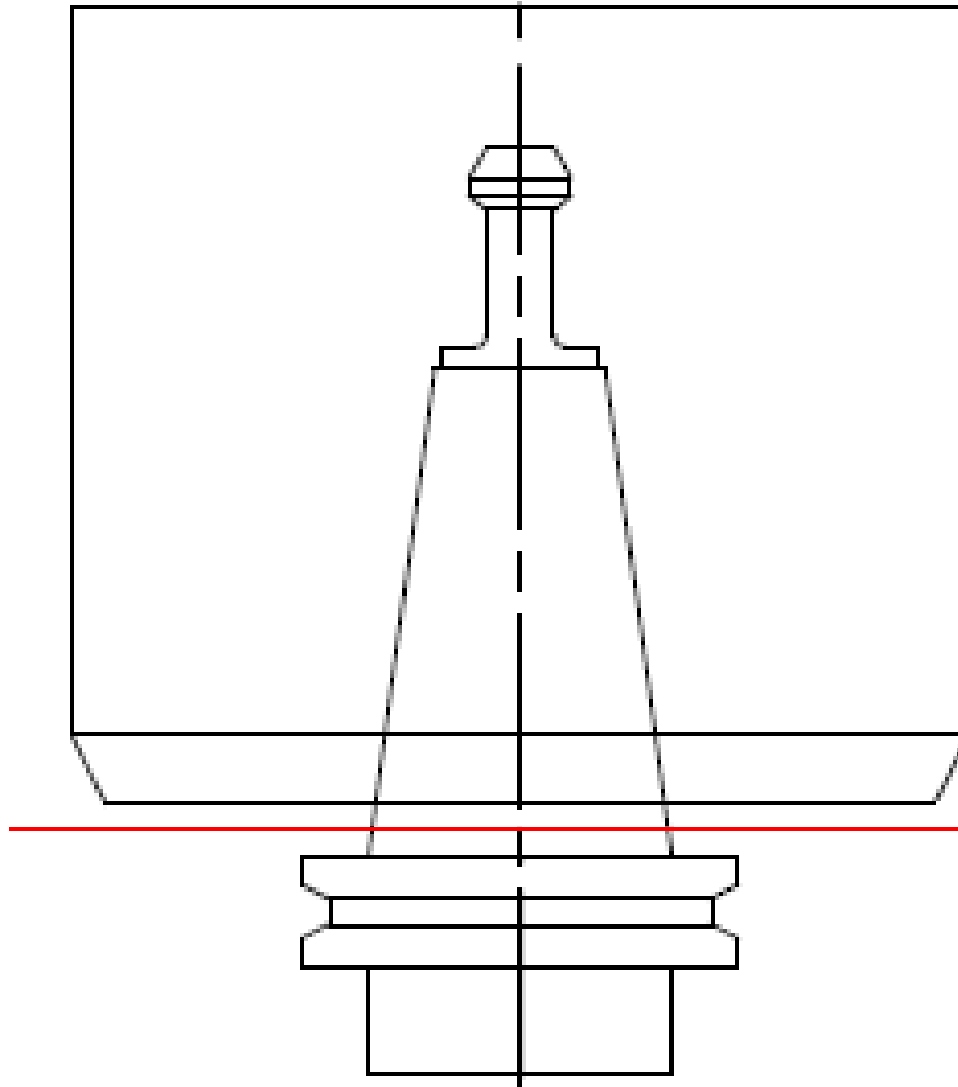

- The spindle gage-line falls somewhere within the gap between the spindle nose face and the V-flange on the tool holder.
- The location is determined by a specified diameter along the ground taper of the tool.

Spindle Gage-line

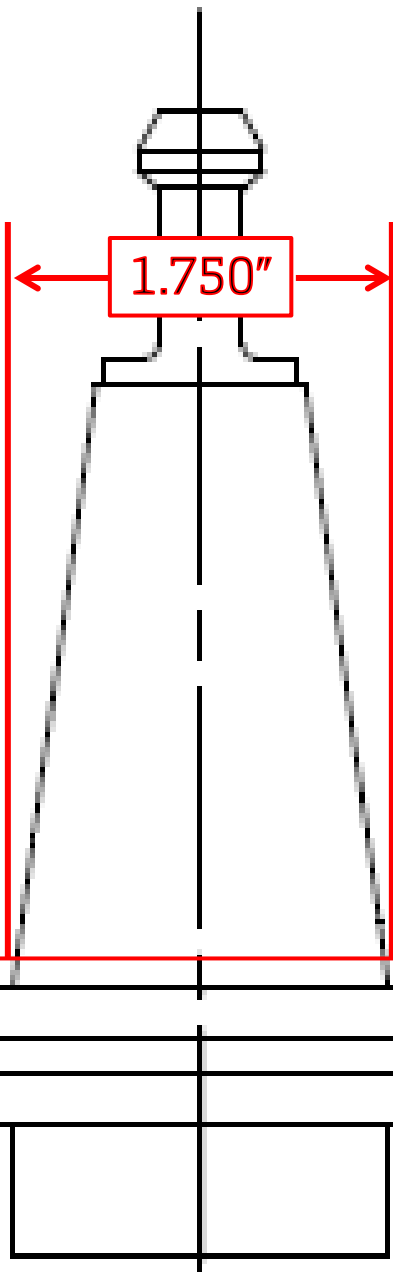

- The specified diameter on a CAT40 holder is 1.75" diameter
- CAT 50 is 2.75" diameter

Spindle Gage-line

Master Reference Tool

What is it?

Master Reference Tool - is a tool of calibrated length that can be mounted in the spindle and used to accurately reference a machine's spindle gage-line. The length is stenciled on the body.



Purchase a Master Reference Tool

Renishaw, Inc. • 5277 Trillium Blvd. • Hoffman Estates, IL 60192 • 847-286-9953

www.renishaw.com

Description:

Part No.

CAT40 Calibration Master

M2253-0954

CAT50 Calibration Master

M2253-0955

BT30 Calibration Master

M2253-1562

HSK63 Calibration Master

M2253-1558

Setting the Z-Reference

Applying the gage-line

The Z-reference dimension is the measured distance between the spindle gage-line and the machine table surface.

Z Reference =
gage-line to table
top surface

TOOL MEASUREMENT SCREEN

TOUCH-OFF DEVICE

	DEVICE	HEIGHT	Z LOCATION	
1	<input type="text" value="PROBE"/>	<input type="text" value="3.5966"/>	<input type="text" value="-16.0389"/>	CAL
2	<input type="text" value="GAUGE"/>	<input type="text" value="1.9685"/>	<input type="text" value="-17.6670"/>	CAL
3	<input type="text" value="GAUGE"/>	<input type="text" value="3.0000"/>	<input type="text" value="-16.6355"/>	CAL
4	<input type="text" value="GAUGE"/>	<input type="text" value="0.0000"/>	<input type="text" value="0.0000"/>	
5	<input type="text" value="GAUGE"/>	<input type="text" value="0.0000"/>	<input type="text" value="0.0000"/>	
6	<input type="text" value="GAUGE"/>	<input type="text" value="0.0000"/>	<input type="text" value="0.0000"/>	

NOTES

Z REFERENCE

Measuring the Z-Reference

How is it calculated?

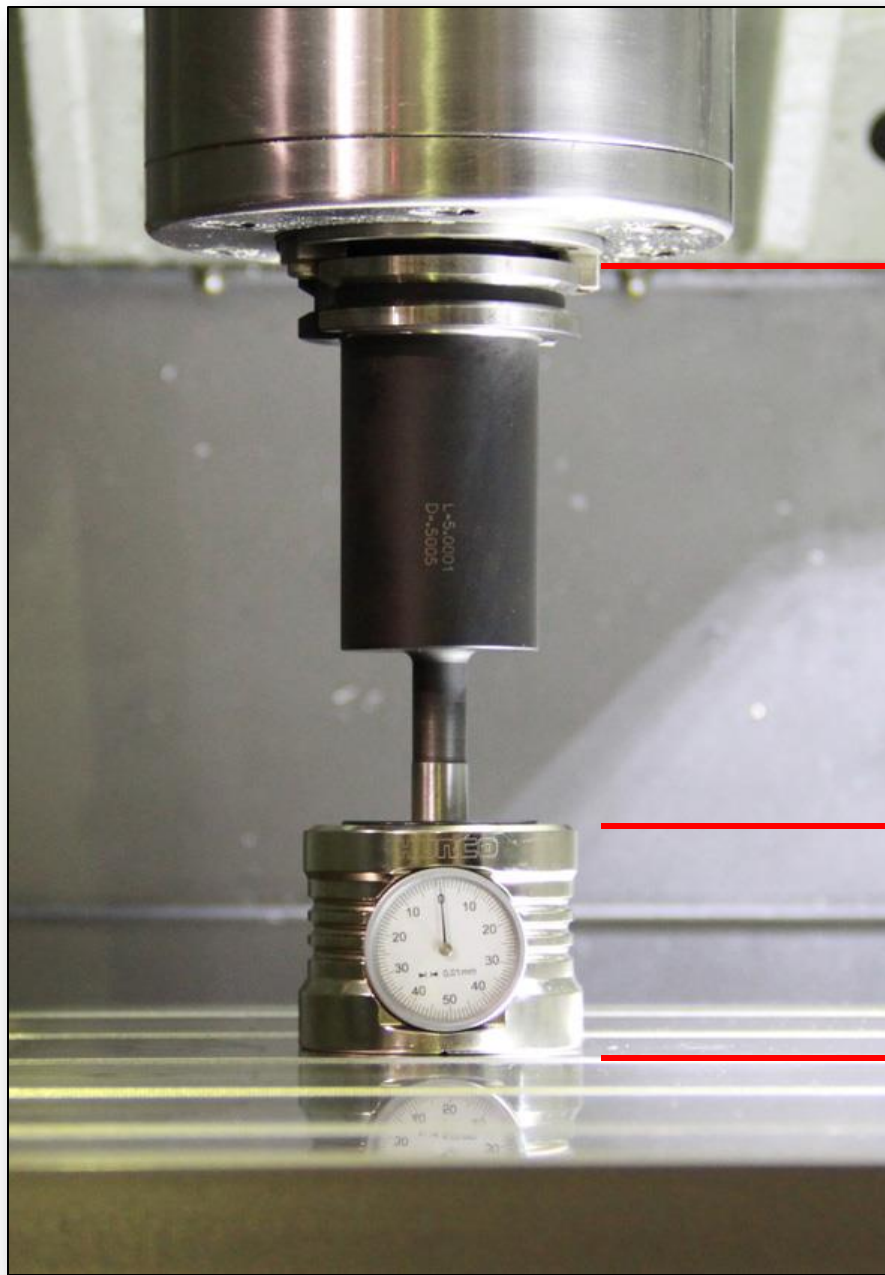

Z-axis Machine Position

+

Master Reference Tool Length

+

Dial Gage Height

=

Z- Reference Dimension

TOOL MEASUREMENT SCREEN

TOUCH-OFF DEVICE

	DEVICE	HEIGHT	Z LOCATION	
1	PROBE	3.5966	-16.0389	CAL
2	GAUGE	1.9685	-17.6670	CAL
3	GAUGE	3.0000	-16.6355	CAL
4	GAUGE	0.0000	0.0000	
5	GAUGE	0.0000	0.0000	
6	GAUGE	0.0000	0.0000	

Z REFERENCE

Top of active device = a calculated location

$$-19.6355 - 1.9685 = -17.6670$$

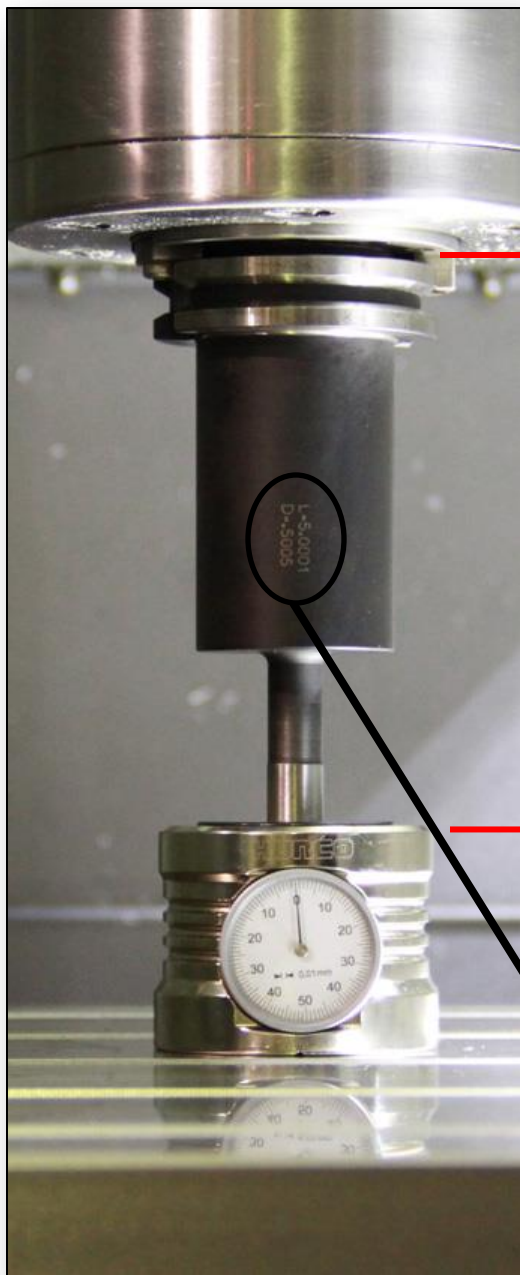

Z-axis Machine Position (-12.6669)

Tool Length (17.6670 - 12.6669 = 5.0001")

Calculated Device Location (-17.6670)

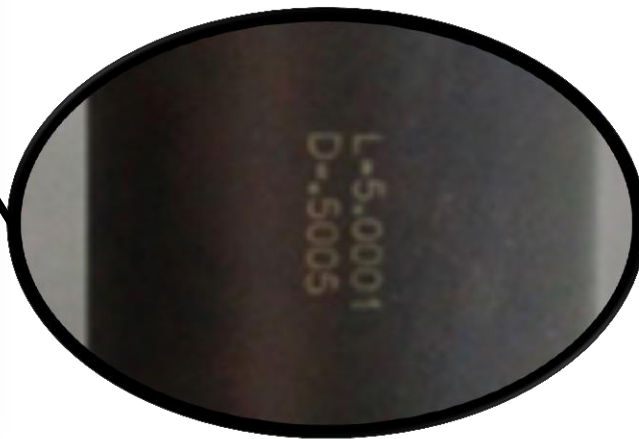

- In 3-axis setups the spindle nose CAN be used, but calculated tool lengths will be “machine specific”, and the tools cannot be shared between other machines.
- Also, offline tool pre-setters cannot be used if tool lengths do not reference the spindle gage-line.

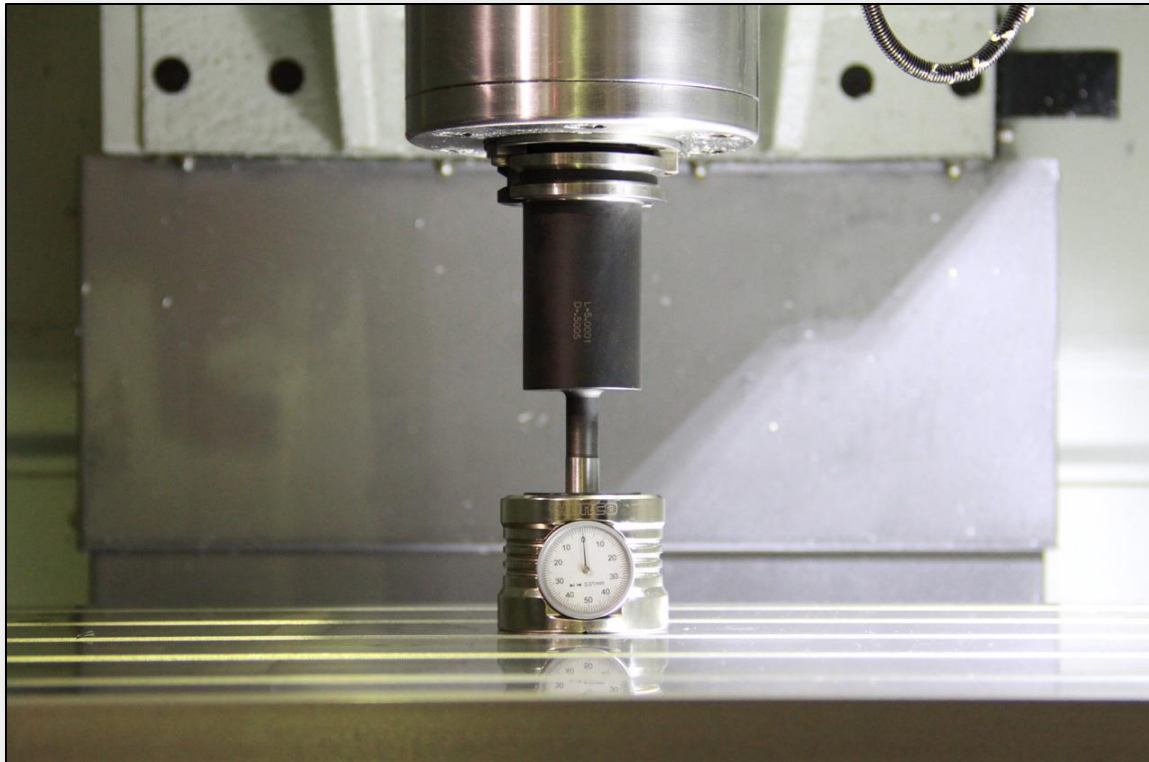

Apply this to 5-axis

Measuring Centerlines

- Rotary axis centerlines are measured from the spindle gage-line in the Z-axis direction.
- Tool lengths **MUST** be measured from the same reference point - or positioning is off location when the part is rotated.

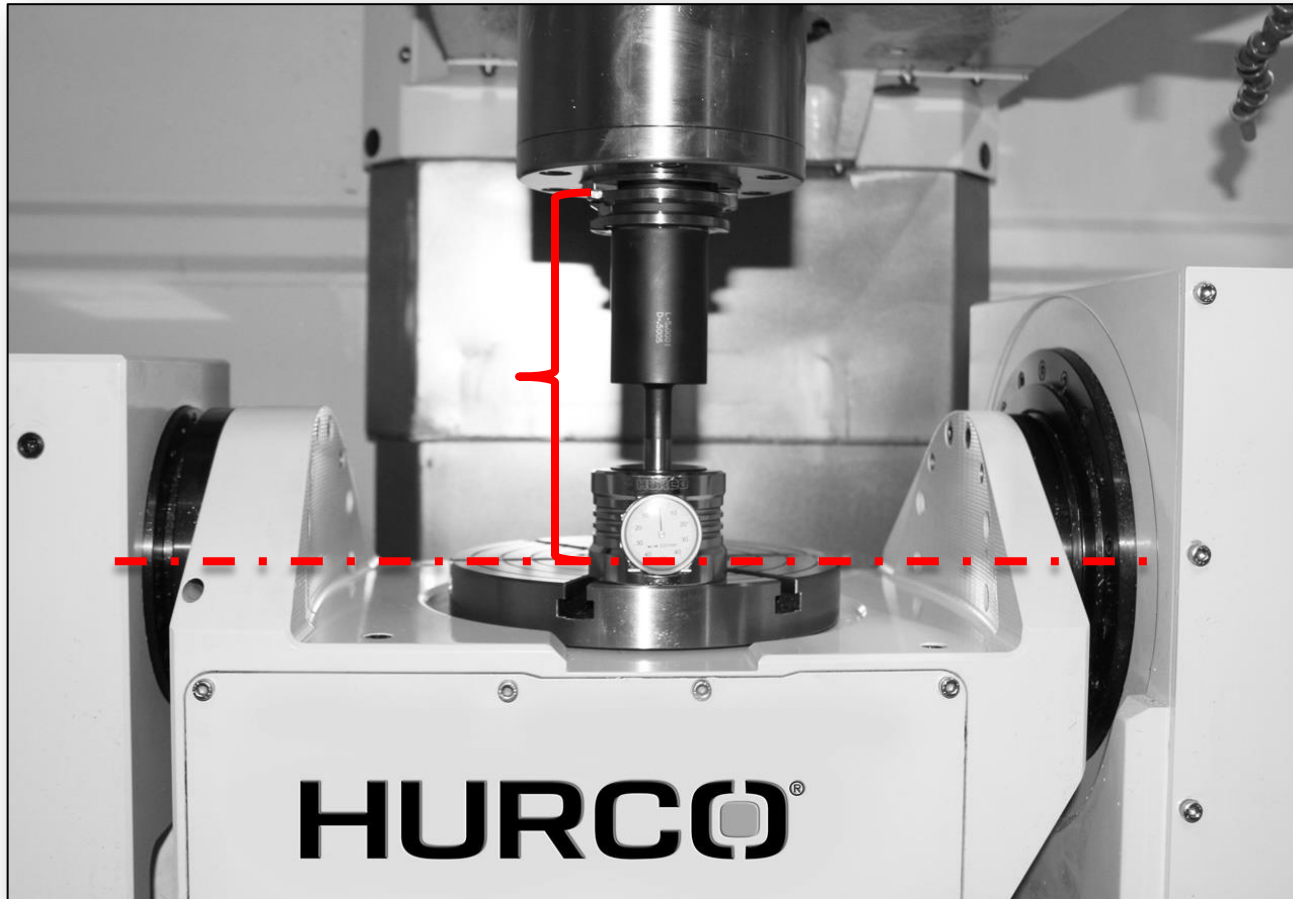

Establish a Setup Device

How do I?

- Absolute Tool Length allows the operator to define and use (6) six different devices to establish a tool's calibrated length.
- The device height is simply an actual measured height of any object to be used to touch-off tools (example: 123 block).

TOOL MEASUREMENT SCREEN

TOUCH-OFF DEVICE

	DEVICE	HEIGHT	Z LOCATION	
1	<input type="text" value="PROBE"/>	<input type="text" value="3.5966"/>	<input type="text" value="-16.0389"/>	CAL
2	<input type="text" value="GAUGE"/>	<input type="text" value="1.9685"/>	<input type="text" value="-17.6670"/>	CAL
3	<input type="text" value="GAUGE"/>	<input style="background-color: #e0f0ff;" type="text" value="3.0000"/>	<input type="text" value="-16.6355"/>	CAL
4	<input type="text" value="GAUGE"/>	<input type="text" value="0.0000"/>	<input type="text" value="0.0000"/>	
5	<input type="text" value="GAUGE"/>	<input type="text" value="0.0000"/>	<input type="text" value="0.0000"/>	
6	<input type="text" value="GAUGE"/>	<input type="text" value="0.0000"/>	<input type="text" value="0.0000"/>	

NOTES

Z REFERENCE

- > Select the active Touch-Off Device.
- > Verify the correct device is active when calibrating tools.

TOOL SETUP

	MACHINE	PART		
X	0.0000	0.0000	A	0.0000
Y	0.0000	0.0000	C	0.0000
Z	0.0000	0.0000	TOOL IN SPINDLE	

TOOL NUMBER	1	LOCATION	Ma
TOOL TYPE		END MILL	
DIAMETER	0.5000	SPEED	CW
		COOLANT	
		SURFACE SPEED	
TOOL CAL LENGTH	5.3266	FEED/FLUTE	
TOUCH-OFF DEVICE	3 GAUGE	FLUTES	
		FEED	
		CUTTING TIME	12 / 0
		DIAMETER WEAR	0.0000

TOOL MEASUREMENT SCREEN

TOUCH-OFF DEVICE DEVICE 3 ▾

	DEVICE	HEIGHT	Z LOCATION	
1	PROBE ▾	3.5966	-16.0389	CAL
2	GAUGE ▾	1.9685	-17.6670	CAL
3	GAUGE ▾	3.0000	-16.6355	CAL
4	GAUGE ▾	0.0000	0.0000	
5	GAUGE ▾	0.0000	0.0000	
6	GAUGE ▾	0.0000	0.0000	

NOTES DEVICE 3 ▾

123 Block on Table Surface

- If one of the devices to be used is a probe, the device type will be set to Probe instead of Gauge.
- Height is the distance from the table surface to the probe stylus surface or laser beam – should be established at install.

TOOL MEASUREMENT SCREEN

TOUCH-OFF DEVICE

	DEVICE	HEIGHT	Z LOCATION	
1	<input type="text" value="PROBE"/>	<input type="text" value="3.5966"/>	<input type="text" value="-16.0389"/>	CAL
2	<input type="text" value="GAUGE"/>	<input type="text" value="1.9685"/>	<input type="text" value="-17.6670"/>	CAL
3	<input type="text" value="GAUGE"/>	<input type="text" value="3.0000"/>	<input type="text" value="-16.6355"/>	CAL
4	<input type="text" value="GAUGE"/>	<input type="text" value="0.0000"/>	<input type="text" value="0.0000"/>	
5	<input type="text" value="GAUGE"/>	<input type="text" value="0.0000"/>	<input type="text" value="0.0000"/>	
6	<input type="text" value="GAUGE"/>	<input type="text" value="0.0000"/>	<input type="text" value="0.0000"/>	

NOTES

Z REFERENCE

GAUGE BLOCK F1

TOOL PROBE F2

F3

F4

F5

F6

